

Rebel 80 Servo V3

Short Bar Loader for Fixed Headstock CNC Lathes

EDGE TECHNOLOGIES



Diameter range: 8mm to 80mm (0.315" to 3.150")

Bar length: 1520mm (60") Not to exceed spindle length**

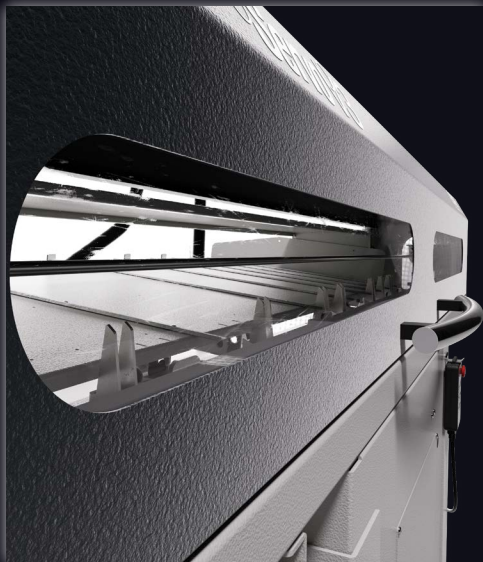

Compact and Robust.

Expanded viewing windows allow for ease of setup and visual monitoring.

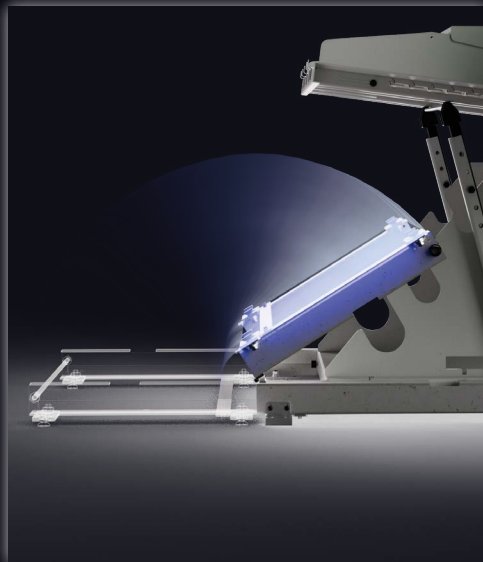

Folding Axial Shift. The folding axial shift allows for easy maintenance and spindle liner changes. The shifting device is standard in X-axis, optional with Z-axis.



Touchscreen HMI Control. The HMI is powerful and user friendly, with 300-part program storage. Schneider PLC motion control is Ethernet ready.

Rebel 80 Servo V3

Short Bar Loader for Fixed Headstock CNC Lathes



Technical Data

Bar Diameter

8mm (0.315") - 80mm (3.15")*

Bar Length

Min - 280mm (11")
Max - 1520mm (60")*
(must not exceed spindle length)

Rapid Return Rate

1300mm/sec. (4ft/sec.)

Bar Change Time

Approx. 22 seconds

Operating Voltage

Electric supply 230V (60HZ) 3-ph

Bar Pushers

Ø 10mm Hardened steel

Ø 19mm Hardened steel

(Ø 6mm optional)

Weight

1100 lbs

Bar Weight

150 lbs per bar

1500 lbs magazine max

300 Part Program Storage

PLC motion control is Ethernet ready.

Slug Load Option Available

Specifications

Bar Size	Rack Capacity	Bar Length*	X & Z Axial Track Travel
8mm (0.315") - 80mm (3.15")	700mm (28") deep	1520mm (60")*	X Axis = 740mm Z Axis = 740mm

* Not to exceed spindle length

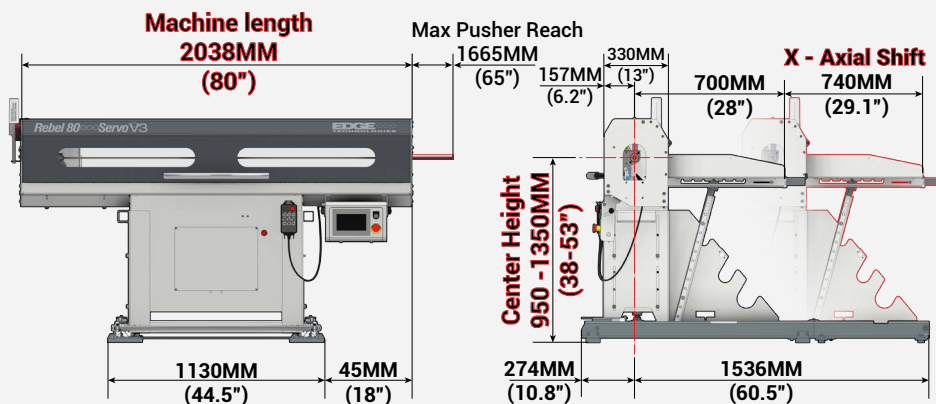
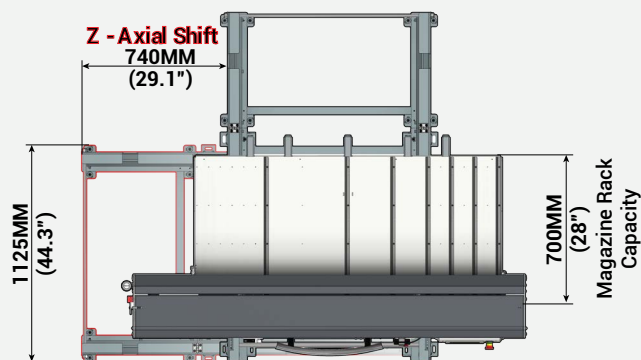

Loading Configuration

Rear Load

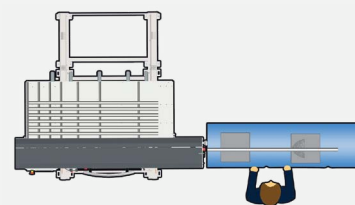

Feeding from rear

Front Load

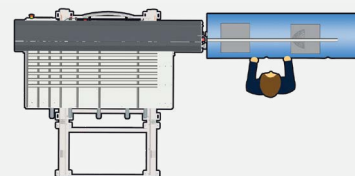

Feeding from front

Edge Technologies

Bar feeding has remained the focus at Edge Technologies for 40+ years. Experience and breadth of model offerings drive our customer-centric approach to solving your bar feeding needs. Service, parts, and technical support have always been the backbone of the company, because we understand that performance and up-time of a bar feeder is a difference maker to your bottom line.

Scan here for more information about the Rebel 80 Servo V3



314.692.8388

15703 Westport Commerce Drive
Ste. 100
Maryland Heights, MO 63146

www.edgetechnologies.com